

Lithium Coin Cell - CR 2450 V3

- Reliable energy for your application
- Standard cells and customized packs
- ESD protection
- UL recognized
- Battery Certification Experts



RoHS compliant



Pb free



REACH compliant



Conflict mineral free

Technical Data Sheet · CR 2450 V3

SPECIFICATIONS

Nominal Voltage	3V
Jauch part number	247288
Nominal Capacity	610 mAh
Standard Load	7.5 kΩ
Standard Current	0.4 mA
Max. Continuous Current	4 mA
Max. Pulse Current	15 mA
Operating Temperature	-30°C to +70°C*
Weight	Approx. 7 gr.
Chemistry	Li/MnO ₂
UI1642	MH62838

* In applications where the battery is exposed to temperatures >60°C, please contact Jauch.

DIMENSIONS

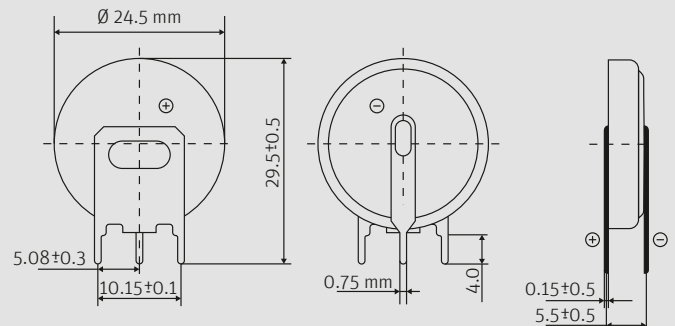

DISCHARGE CHARACTERISTICS

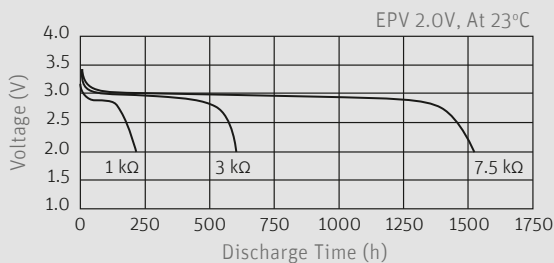

TEMPERATURE CHARACTERISTICS

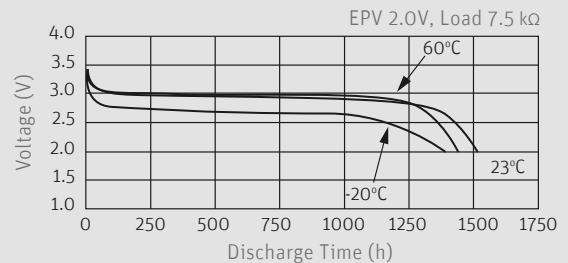

PULSE DISCHARGE CHARACTERISTICS

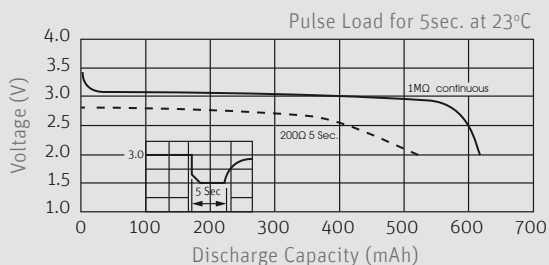

LOAD VS: CAPACITY

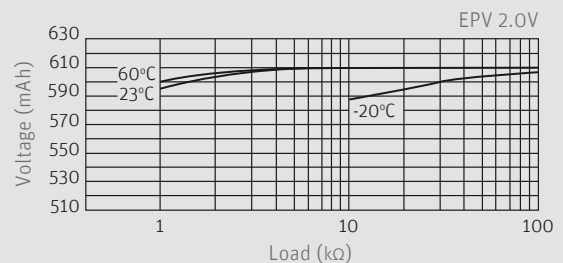

Wide assortment of mounting options, including through hole, surface mount and wire terminals.

This information is generally descriptive only and is not intended to make or imply any representation, guarantee or warranty with respect to any cells and batteries. Cell and battery designs/specifications are subject to modification without notice. Contact us for the latest information.