

Jauch Battery Solutions

- Reliable energy for your application
- Standard cells and customized packs
- ESD protection
- Battery Certification Experts



RoHS compliant



Pb free



REACH compliant



Conflict mineral free

Technical Data Sheet · ER14335J-P

SPECIFICATIONS

Cell Size reference	2/3 AA
Chemistry	Li-SoCl ₂
UL 1642	MH62838
Nominal Voltage	3.6V
Jauch No.	247833
Nominal Capacity	1.65 Ah
Max. Continuous Current	75 mA
Max. Pulse Current	150 mA (150mA/0,1 sec pulses, drained every 2 min at 25°C)
Operating Temperature	-60°C to +85°C*
Storage	30°C max
Weight	Approx. 12 gr.

* In applications where the battery is exposed to temperatures >85°C, please contact Jauch.

DIMENSIONS

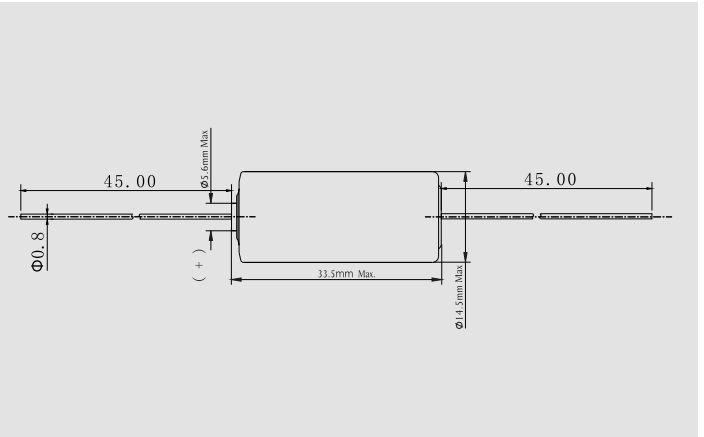

Available Terminals and Wire Connectors: please contact Jauch for diagram of batteries with terminals (batterytechnology@jauch.com).

DISCHARGE CHARACTERISTICS

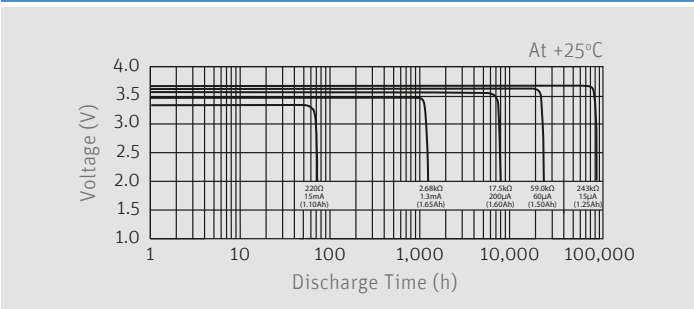

VOLTAGE VS. TEMPERATURE

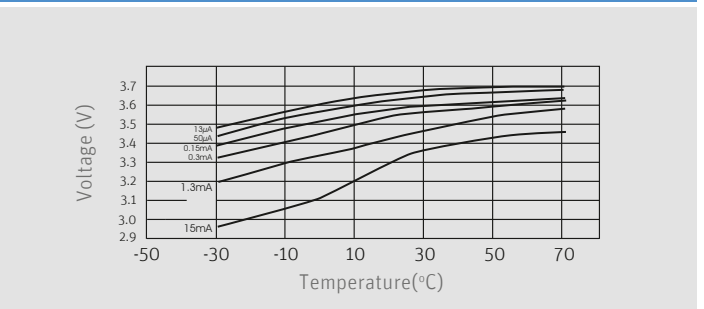

CAPACITY VS. CURRENT

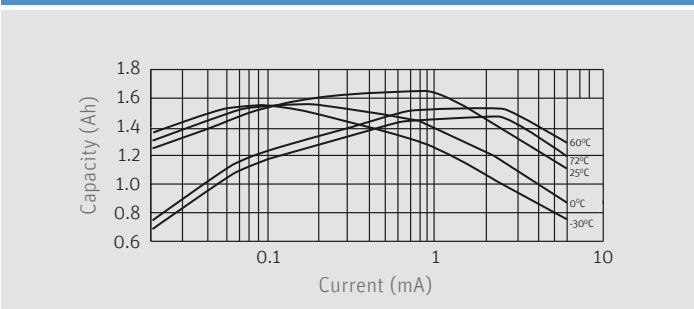

STORAGE CHARACTERISTICS

