

# Jauch Battery Solutions



RoHS compliant

Pb free



REACH compliant



Conflict mineral free



- Reliable energy for your application
- Standard cells and customized packs
- ESD protection
- Battery Certification Experts

## Technical Data Sheet · ER14505J-P

### SPECIFICATIONS

Cell Size reference	AA
Chemistry	Li-SoCl <sub>2</sub>
UL 1642	MH62838
Nominal Voltage	3.6V
Jauch No.	247834
Nominal Capacity	2.6 Ah
Max. Continuous Current	100 mA
Max. Pulse Current	200 mA (200mA/0,1 sec pulses, drained every 2 min at 25°C)
Operating Temperature	-55°C to +85°C*
Storage	30°C max
Weight	Approx. 19 gr.

\* In applications where the battery is exposed to temperatures >85°C, please contact Jauch.

### DIMENSIONS

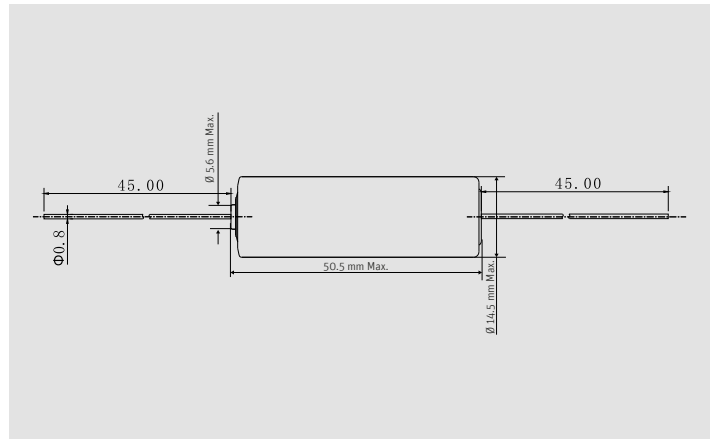

**Available Terminals and Wire Connectors:** please contact Jauch for diagram of batteries with terminals ([batterytechnology@jauch.com](mailto:batterytechnology@jauch.com)).

### DISCHARGE CHARACTERISTICS

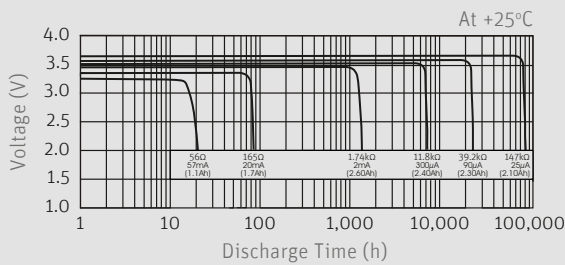

### VOLTAGE VS. TEMPERATURE

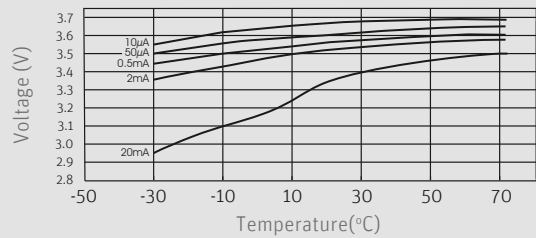

### CAPACITY VS. CURRENT

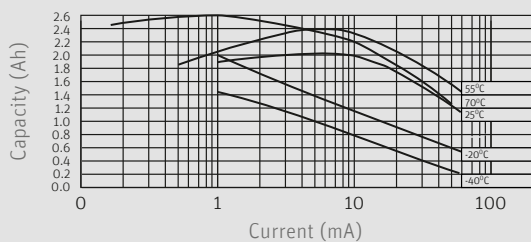

### STORAGE CHARACTERISTICS

