



# Jauch Battery Solutions

- Reliable energy for your application
- Standard cells and customized packs
- ESD protection
- Battery Certification Experts



RoHS compliant



Pb free



REACH compliant



Conflict mineral free

## Technical Data Sheet · ER18505J-S

### SPECIFICATIONS

Cell Size reference	A
Chemistry	LiSoCl <sub>2</sub>
UL 1642	MH62838
Nominal Voltage	3.6V
Jauch No.	248268
Nominal Capacity	4.0 Ah
Max. Continuous Current	130 mA
Max. Pulse Current	180 mA (180mA/0,1 sec pulses, drained every 2 min at 25°C)
Operating Temperature	-60°C to +85°C*
Storage	30°C max
Weight	Approx. 28 gr.

\* In applications where the battery is exposed to temperatures >85°C, please contact Jauch.

### DIMENSIONS

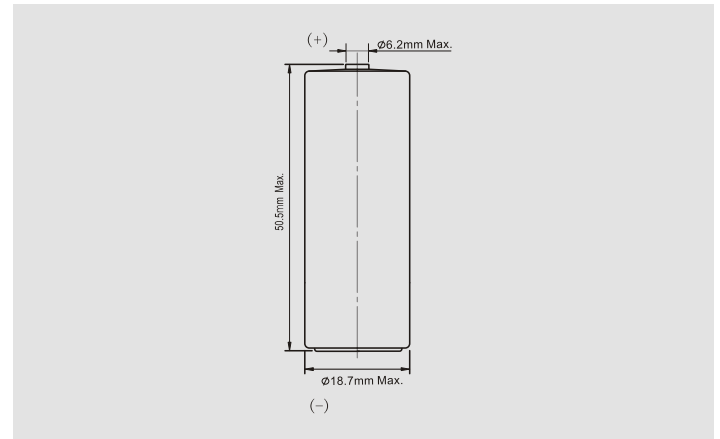

**Available Terminals and Wire Connectors:** please contact Jauch for diagram of batteries with terminals (batterytechnology@jauch.com).

### DISCHARGE CHARACTERISTICS

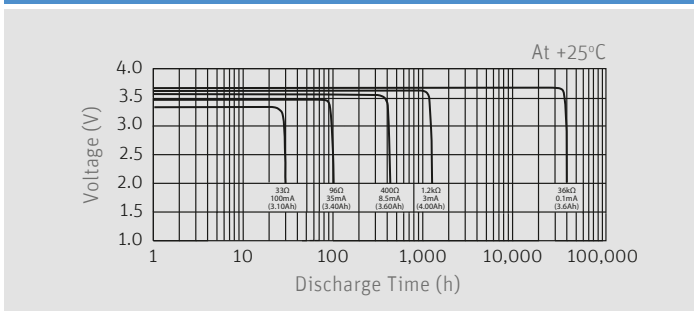

### VOLTAGE VS. TEMPERATURE

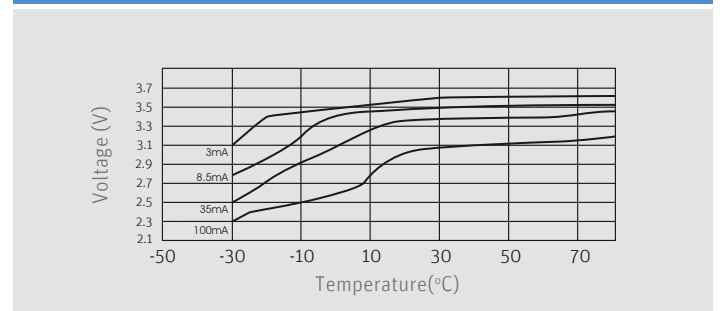

### CAPACITY VS. CURRENT

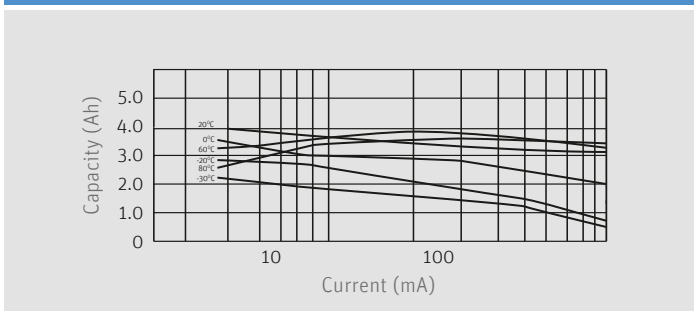

### STORAGE CHARACTERISTICS

