



actual size

Oscillator JO32 · 32.768 kHz · AT-cut

- SMD Oscillator with Stop Function · 3.2 x 2.5 mm
- High frequency stability up to +125 °C
- Variable supply voltage 1.8 V ~ 3.3 V
- Very low current consumption
- Seam sealed ceramic/metal package



RoHS compliant



Pb free



REACH compliant



Conflict mineral free

GENERAL DATA		
TYPE	JO32 32.768 kHz AT-cut 1.8 V ~ 3.3 V	
frequency	32.768 kHz	
frequency stability over all*	± 25 ppm ~ ± 100 ppm (table 1)	
current consumption	see table 2	
supply voltage V _{DC}	1.8 V -10 % ~ 3.3 V +10 % variable	
temperature	operating	-10 °C ~ +70 °C up to -40 °C ~ +125 °C (table 1)
	storage	-55 °C ~ +125 °C
output	rise & fall time	50 ns typ. / 200 ns max.
	load max.	15 pF
	current max.	0.8 mA
	low level max.	0.4 V
	high level min.	V _{DC} - 0.4 V
output enable time max.	10 ms	
output disable time max.	1 µs	
start-up time max.	10 ms (t ₀ when V _{DC} > 1.8 V)	
standby function	stop	
standby current max.	10 µA (T1) / 20 µA (T2, T3)	
symmetry at 0.5 x V _{DC}	45 % ~ 55 % max. (ref. +25 °C)	

note: rise time: 0.1 VDC ~ 0.9 VDC / fall time: 0.9 VDC ~ 0.1 VDC

TABLE 1: FREQUENCY STABILITY CODE				
stability code / temp. code	A	B	G	C
	± 100 ppm	±50 ppm	± 30 ppm	± 25 ppm
-20 °C ~ +70 °C	○	○	○	○
-40 °C ~ +85 °C	T1	○	○	
-40 °C ~ +105 °C	T2*	○		
-40 °C ~ +125 °C	T3*	○		

○ available

includes stability at 25 °C, operating temp. range, supply voltage change, shock and vibration, aging 1st year

* ask for availability

TABLE 2: CURRENT CONSUMPTION MAX.				
Supply current max.	load	1.8 V	2.5 V	3.3 V
at 32.768 kHz	5 pF	225 µA	230 µA	235 µA
	10 pF	230 µA	235 µA	240 µA
	15 pF	235 µA	240 µA	245 µA

note: please also refer to I/V plots showing typical supply current at 5 pF / 10 pF / 15 pF

DIMENSIONS

top view side view bottom view pad layout pin connection in mm

1: e/d
2: ground
3: output
4: V_{DC}

ORDER INFORMATION

0	frequency	type	frequency stability code	supply voltage code	output load code	option
Oscillator	0.032768 = 32.768 kHz	JO32	see table 1	1V3 = 1.8 V ~ 3.3 V	1 = 15 pF	blank = -20 °C ~ +70 °C T1 = -40 °C ~ +85 °C T2 = -40 °C ~ +105 °C T3 = -40 °C ~ +125 °C

Example: 0 0.032768-JO32-G-1V3-1-T1-LF (Suffix LF = RoHS compliant / Pb free)

Oscillator J032 · 32.768 kHz · AT-cut · Stop Function

TYPICAL SUPPLY CURRENT VS. V_{DC} AT DIFFERENT LOAD CAPACITANCES

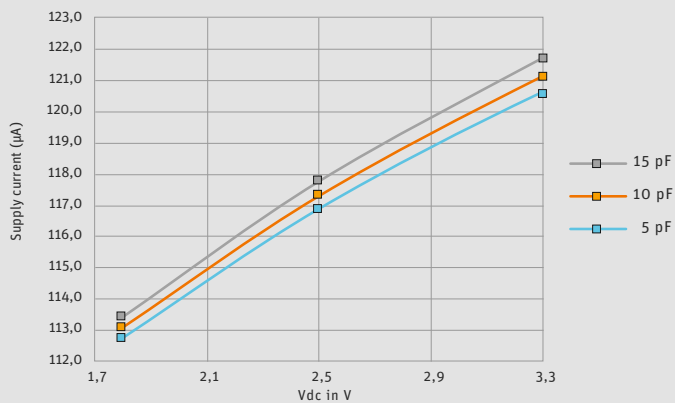

ENABLE / DISABLE FUNCTION

pin #1 (e/d control)	pin #3 (output)
open	active
high "1" ($V_{IH} \geq 0.7 V_{DC}$)	active
low "0" ($V_{IL} \leq 0.3 V_{DC}$)	high impedance

stop function:

- oscillator stops
- output high impedance

PACKAGING NOTE

- standard packing unit is 500 pieces per reel
- non-multiple packing units are only supplied taped / bulk

TAPING SPECIFICATION

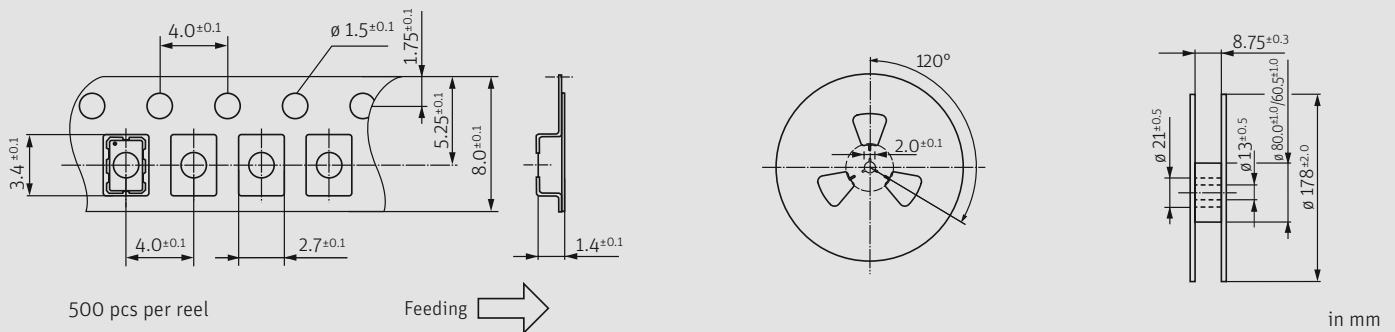

REFLOW SOLDERING PROFILE

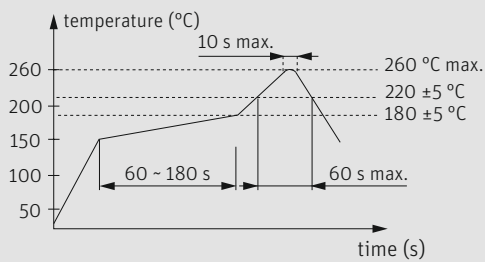

note: parts are also suitable for soldering systems with lead (Pb) content

MARKING

frequency
company / stability code / date code

date code: A ~ M: Jan. - Dec.

9: 2019 0: 2020 1: 2021 2: 2022 3: 2023 4: 2024

Jan.	Febr.	Mar.	Apr.	May	June
A	B	C	D	E	F
July	Aug.	Sept.	Oct.	Nov.	Dec.
G	H	J	K	L	M